

The best Choice for Duties in Process and Utilities

BaseLine Plate Heat Exchangers

Application

Cooling and heating of dairy, brewery, beverage and viscous products and pasteurization in some applications.

Working principle

The plate heat exchanger consists of a pack of corrugated metal plates with portholes for the passage of two fluids between which heat transfer will take place.

The plate pack is assembled between a frame plate and a pressure plate and compressed by tightening bolts.

The plates are fitted with a gasket which seals the channel and directs the fluids into alternate channels. The number of plates are determined by the flow rate, physical properties of the fluids, pressure drop and temperature program. The plate corrugations promote fluid turbulence and support the plates against differential pressure.

Frame

The plates and the pressure plate are located by an upper bar and a lower bar, both of which are fixed to the support column. On the largest type some tightening bolts are equipped with ball bearing washers in order to facilitate opening and closing of the unit. The frame is designed for mounting on a floor only. Standard feet are fixed.

One unit can contain several sections, separated by connection plates with interchangeable connections. (Not valid for M3-Base).

Plates

The corrugation of the plates provides a passage between the plates, supports each plate against the adjacent one and enhances the turbulence, resulting in efficient heat transfer. Corner ports and gaskets are arranged so that the two media flow through alternate channels.

The plates have a chevron pattern for maximum strength at high working pressures. Different chevron designs are available, in order to obtain optimal high heat transfer and low pressure drop.

A unique distribution area provides an even flow over the plate surface.

The plates are reversible and have parallel flow, which means only one type of plate is needed.



BaseLine

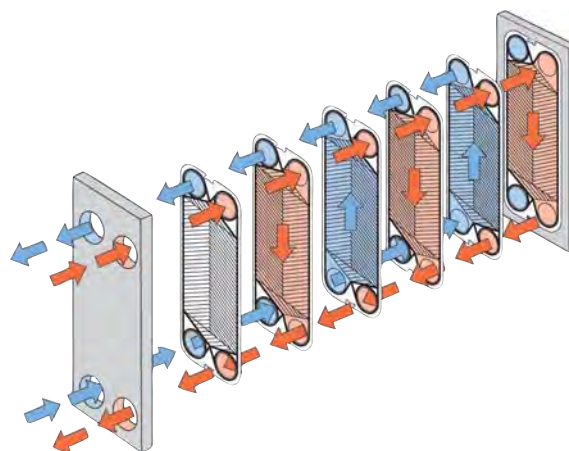

Flow principle of a plate heat exchanger

Gaskets

The plates are supplied with glue-free Clip-On gaskets, which are easy to replace even with the plates still standing in the frame.

BaseLine

Plate Types

M3, M3G, M6, M6M, M6MG, M10B, M10M and TL10B

Standard Materials

Plates

Stainless steel AISI 304, AISI 316, titanium or SMO.

Gaskets

Nitrile-FDA, EPDM or EPDM-FDA.

Clip-On design.

Frame

Frame and pressure plate in solid stainless steel for Base 3, 6 and 10. Outer surfaces in various grades of stainless steel. Movable nuts on tightening bolts in chromium plated brass

Technical Data

Mechanical design pressure (g) / Temperature

10 bar/160°C

According to European pressure vessel directive (PED).

Connections

Threaded unions – male part

DIN 11864-1 (Range A), DIN 11851, SMS 1146, BS/RJT 4825 Part 5, IDF/ISO 2853

Clamp unions – ferrule end

ISO 2852 (Tri-clamp)

Optional

- A. Protection sheet
- B. 3-A finish
- C. Adjustable legs, low or high
- D. Wrench
- E. Test certificates and material certificate
- F. Testing by authorized inspection companies

All options are not available on all models.

Dimensions (mm)

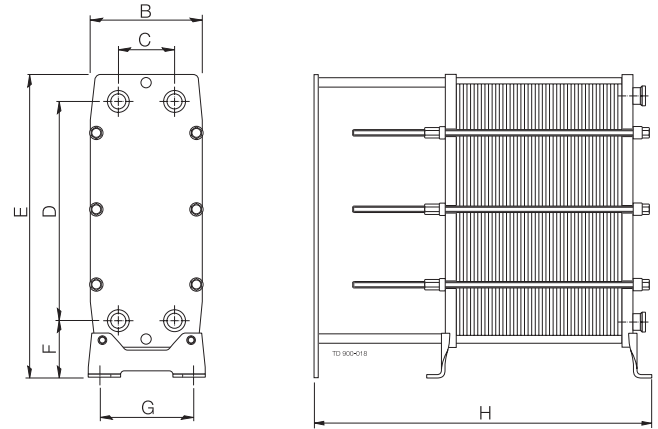

Dimensions	BASE-3	BASE-6	BASE-10	BASE-11
B	180	304	446	473
C	60	140	223	218
D	357	640	719	1338
E	545	909	1053	2087
F	141	181	214	430
G	176	290	430	590
H	250-510	575-1925	700-2200	1100-3000

Connection				
Diameter mm	25	51	76/101.6	76/101.6

Capacity l/h				
Pasteurization	-	11,000	15,000	25,000*
Heating/Cooling	4,500	15,000	65,000	70,000*
Water	8,800	35,000	130,000	130,000*

* only recommended for low pasteurization applications.

The number of tightening bolts vary for different types. Recommended free space around the unit is 1.0 meter at sides and frame head end.