



The Premium Pump for Higher Pressure

Alfa Laval LKHI Centrifugal Pump for 16 bar Inlet Pressure

Application

The LKHI pump is a highly efficient and economical centrifugal pump, specially designed for inlet pressures up to 16 bar. LKHI meets the requirements of sanitary and gentle product treatment and chemical resistance, and is available in nine sizes, LKHI-10, -15, -20, -25, -35, -40, -45, -50, -60.

Standard Design

The LKHI pump is designed for CIP-cleaning with emphasis on large internal roundings and easily cleanable seals.

LKHI is a sanitary pump with a stainless steel shroud for protection of the motor. The complete unit is supported on four adjustable stainless steel legs.

Shaft seals

LKHI can be fitted with two types of mechanical seals:

- Single internal seal.
- Flushed seal.

Both seal types have stationary seal rings of silicon carbide and rotating seal rings of carbon or silicon carbide:

1. Silicon carbide/carbon for inlet pressure up to 10 bar.
2. Silicon carbide/silicon carbide for inlet pressure higher than 10 bar.

The secondary seal of the flushed seal is a long lasting lip seal.



TECHNICAL DATA

Product wetted steel parts: W. 1.4404 (316L).
 Other steel parts: Stainless steel.
 Product wetted seals: EPDM.
 Other O-rings: EPDM.
 Finish: Semi-bright.

Connections for flushed shaft seal:

6 mm tube/Rp 1/8"

Motor

Foot-flanged motor according to the IEC metric standard, 2 poles = 3000/3600 rpm. at 50/60 Hz, IP 55 (with drain hole with labyrinth plug), insulation class F.

Motor types:

Inlet pressure 0-10 bar: .Standard motor with a fixed ball bearing on drive side.

Inlet pressure 10-16 bar .Special motor with a fixed angular-contact ball bearing on drive side.

Motor sizes

50 Hz: 1.5 - 30.0 kW.
 60 Hz: 1.75 - 35.0 kW

OPERATING DATA

Pressure

Max. inlet pressure: 1600 kPa (16 bar).
 Water pressure: Normally atmospheric.
 (max. 1 bar).

Temperature

Temperature range: -10°C to +140°C (EPDM).

Water consumption

Water consumption: 0.25 -0.5 l/min.
 (Flushed seal)

Noise

Noise level (at 1 m): 60 - 80 dB (A).
 Noise level (at 3 ft.): 60 - 80 dB (A).

Dimensions (mm)

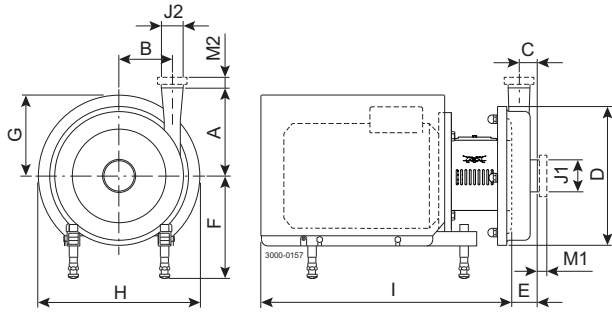

Volumetric flow

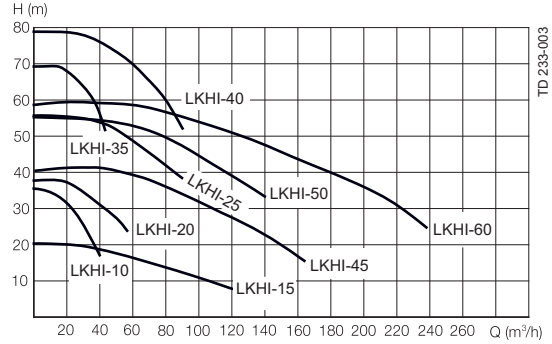

Pump specific measures

Pump Model	LKHI-10	LKHI-15	LKHI-20	LKHI-25	LKHI-35	LKHI-40	LKHI-45	LKHI-50	LKHI-60
A	142	166	180	193	193	212	212	205	261
B	87	66	88	106	119	126	126	118	102
C	23	43	27	32	23	28	28	35	62
D	247	247	253	303	303	329	329	329	329
E	51	87	63	69	54	64	64	77	106

Motor specific measures

Motor IEC	IEC90	IEC100	IEC112	IEC132	IEC160	IEC180	IEC200
Motor kW	1.5/2.2	3.0	4.0	5.5/7.5	11/15/18.5	22	30
F(max)*	262	282	285	304	332	352	372
G	157	185	198	196	262	286	399
H	288	325	359	383	485	533	670
I	434	516	497	597	791	842	980

*Possible to reduce dimension F by min. XX mm for all pump models. For smaller models it will be possible to reduce dimension F even further.

Motor overview

Pump Model	LKHI-10	LKHI-15	LKHI-20	LKHI-25	LKHI-35	LKHI-40	LKHI-45	LKHI-50	LKHI-60
Motor range (IEC)	IEC90- IEC112	IEC100- IEC132	IEC90- IEC132	IEC132- IEC160	IEC112- IEC160	IEC132- IEC180	IEC112- IEC160	IEC132- IEC180	IEC132- IEC200

Dimensional data are based on 2 pole, ABB motors.

Connections

Pump Model		LKHI-10 LKHI-20 LKHI-35	LKHI-15 LKHI-45 LKHI-50	LKHI-25	LKHI-40	LKHI-60
Clamp ISO 2037	M1	21	21	21	21	21
	M2	21	21	21	12	21
Union ISO(IDF)	M1	21	21	21	21	21
	M2	21	21	21	21	21
Union DIN/ISO	M1	25	30	30	30	30
	M2	22	30	25	27	30
Union SMS	M1	24	35	24	24	35
	M2	20	24	24	24	35
Union (BS)RJT	M1	27	32	27	27	32
	M2	27	27	27	22	32
Union DS	M1	24	24	24	24	24
	M2	20	24	24	21	24
J1*		63,5 / 2,5"	101,6 / 4"	76,1 / 3"	76,1 / 3"	101,6 / 4"
J2*		51 / 2"	76,1 / 3"	63,5 / 2,5"	63,5 / 2,5"	101,6 / 4"

* Other dimensions available on request.

Options

- A. Impeller with reduced diameter.
- B. Impeller screw.
- C. Motor for other voltage and/or frequency.
- D. 1500 rpm. motor.
- E. Motor with increased safety/flame proof motor.
- F. Flushed shaft seal.
- G. Seals in Nitrile (NBR) or Fluorinated rubber (FPM).
- H. Surface roughness, product wetted parts: $R_a \leq 0.8 \mu\text{m}$.
- I. Seal faces in SIC/SIC (Silicon Carbide).

Ordering

Please state the following when ordering:

- Pump size.
- Pressure.
- Connections
- Impeller diameter.
- Motor size.
- Single or flushed shaft seal.
- Optional extras.

Note!

- The curves for LKHI are the same as those for LKH.
- For further details, see also Instruction Manual, ESE00700.

Alfa Laval reserves the right to change specifications without prior notification. ALFA LAVAL is a trademark registered and owned by Alfa Laval Corporate AB.

ESE00268EN 1507

© Alfa Laval

How to contact Alfa Laval

Contact details for all countries are continually updated on our website. Please visit www.alfalaval.com to access the information direct.